

# Remote Learning

Grade 1

-Mrs Ryan-



REMOTE LEARNING GUIDE- MAY 31st to June 3rd



Please find below a timetable for remote learning.

Please return your child's work with their name on it. Please return on Friday June 4th.

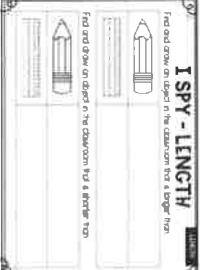
	<b>Webex- 9.00am</b> Refer to you pack for meeting number and password	<b>Webex- 9.00am</b> Refer to you pack for meeting number and password	<b>Webex- 9.00am</b> Refer to you pack for meeting number and password	<b>Webex- 9.00am</b> Refer to you pack for meeting number and password	
<b>Day</b>	<b>Monday</b>	<b>Tuesday</b>	<b>Wednesday</b>	<b>Thursday</b>	
<p><b>Reading fluency</b> At least 10 - 15 minutes daily</p>	<p>Practice reading your books. Read aloud, read to yourself, even try recording your reading on a device. Read your Sounds-Write words (Grade Preps and Ones) and Oxford words (Grade Ones). You may also like to build your Sounds-Write words using the letter tiles provided.</p>				
<p><b>Reading 20-30 min.</b> Read a book from your reader cover or Wushka and complete the activity.  * Ensure your child reads a new book each day. * If capable, they can read more than one book and repeat the activity.</p>	<p>Read a book, and talk with an adult about what happened at the <b>end of the story.</b>  Draw a picture and write a sentence about the story ending.  *Complete this task using the sheet provided in your remote learning booklet.  *Parents/Older sibling can write the sentence.</p>	<p>Read a book, and talk with an adult about what happened at the <b>beginning and end of the story.</b>  Draw and write about the beginning.  Draw and write about the end.  *Today encourage your child to write keywords or a whole sentence if they can.</p>	<p>Read your book, and talk with an adult about what happened at the <b>beginning, middle and end of the story.</b>  Draw and write about the beginning.  Draw and write about the middle.  Draw and write about the end.</p>	<p>Read your book, and talk with an adult about what happened at the <b>beginning, middle and end of the story.</b>  Draw and write about the beginning.  Draw and write about the middle.  Draw and write about the end.</p>	<p>Read your book, and talk with an adult about what happened at the <b>beginning, middle and end of the story.</b>  Draw and write about the beginning.  Draw and write about the middle.  Draw and write about the end.</p>

<p><b>Writing Fluency</b> 10 - 15 minutes</p>	<p>Practice handwriting and spelling regularly. Spelling suggestions- use Sounds-Write letter tiles, write words in rainbow colours, use finger paint or chalk, go on a word treasure hunt (parents leave words around the room for children to find and copy). Handwriting suggestions- write words that you know such as family names, toys or other items.</p>				
<p><b>Writing 20-30 min.</b> Try writing by yourself, but if a parent helps you with a word that is okay.</p>	<p><b>Weekend recount planner</b> Use the weekend recount planner in your pack.  Draw a picture about your weekend. Write key words (parents can help with this).  You will use this planner to help you write about your weekend tomorrow.</p>	<p><b>Weekend recount</b> Write about what you did on the weekend.  Prep- Using the planner from yesterday, complete your weekend writing with the sentence starter:  'On the weekend I ...' (in your pack)  Grade 1 (and anyone that wants to have a try)- Use the sentence starter 'On the weekend' to begin your writing.  Write about what you did on the weekend in order.  Use capital letters at the beginning of each sentence. Make sure your sentences end with a full stop. Include some keywords at the beginning of each sentence such as, Next, Then, After, etc.</p>	<p><b>Procedure</b> Write a procedure for how you made your breakfast. First draw a picture of your breakfast. For writing remember - Start each step with a number. - Each step is to be written on a new line. See below for an example. Prep- 1. Get a bowl. 2. Add the cornflakes. 3. Add the milk. 4. Eat with a spoon.  Grade 1- 1. Get a bowl. 2. Shake cornflakes into the bowl. 3. Carefully pour in the milk. 4. Enjoy eating your cornflakes with a spoon.  *Parents may help if needed.</p>	<p><b>Letter Writing</b> Write a letter to a friend about what you have done this week during remote learning.  Dear *friend*,  I have had a great time this week.  (Use the sentence starters below as a prompt.)  My favourite thing was... I had a great time... I can't wait to...  From...  (This is an example, try to add some more ideas)</p>	

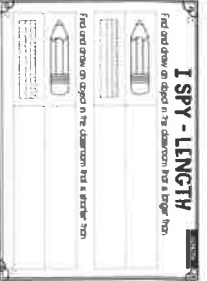
<p><b>Maths Fluency</b> (10 - 15 minutes)</p>	<p>Prep- Practice counting by ones to 20 and beyond. Use materials to support understanding and encourage 1-1 counting, e.g. beads, pegs, blocks, cereal, sultanas, Lego. Grade 1- Practice counting to 100 and beyond. Practice writing numbers.</p>			
<p><b>Maths – Prep (20 minutes)</b></p> <p>*Please feel free to repeat an activity if you do not have the resources available, or use other resources you do have at home.</p> <p>*Go online and use your IXL login. <a href="http://au.ixl.com/signin/woodfordprimary">http://au.ixl.com/signin/woodfordprimary</a> Practice a range of numeracy activities.</p>	<p><b>I spy - Length Worksheet.</b></p>  <p>Find and draw objects that are longer and shorter than the items shown on the worksheet. If you do not have these items at home, choose other items.</p>	<p><b>Measure and order Worksheet.</b></p>  <p>Cut and paste each item and order from shortest to longest.</p>	<p><b>Measure the room Worksheet.</b></p>  <p>Find items in your house to measure. If you can't find the items on the worksheet, find different items and draw them on a blank piece of paper.</p> <p>Measure each item with a range of objects, including hands, paperclips, Lego, pencils, etc.</p> <p>For example, measure a book using Lego pieces. How many Lego pieces did you use? Write this number in the correct box.</p>	<p><b>Measurement at home</b></p> <p>Find 10 items in your house. Order them from shortest to longest. Draw these items in order from shortest to longest on a piece of paper.</p>

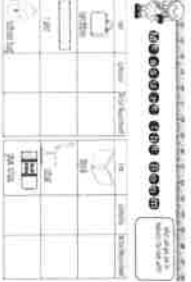
<p><b>Maths - Grade 1 (30 minutes)</b></p> <p>*Please feel free to repeat an activity if you do not have the resources available, or use other resources you do have at home.</p> <p>*Go online and use your IXL login.  <a href="http://au.ixl.com/signin/woodfordprimary">http://au.ixl.com/signin/woodfordprimary</a>  Practice a range of numeracy activities.</p>	<p><b>I spy - Length Worksheet.</b></p>  <p>Find and draw <b>multiple</b> objects that are longer and shorter than the items shown on the worksheet. If you do not have these items at home, choose other items.</p>	<p><b>Measure and order Worksheet.</b></p>  <p>Cut and paste each item and order from shortest to longest. Find 4 more items that are shorter, and 4 more items that are longer than the items on the worksheet. Take a photo of these items when you find them.</p>	<p><b>Measure the room Worksheet.</b></p>  <p>Grade 1 - Complete the activity and order the items from shortest to longest. Make sure each object you are using to measure is the same size and facing the same way.</p>	<p><b>Measurement at home</b></p> <p>Find 10 items in your house. Order them from shortest to longest. Draw these items in order from shortest to longest on a piece of paper. Measure these items with the same objects, e.g. hands, Lego, paperclips.</p>
--	---	--	---	---

## Online Platforms

On Thursday your child was provided sign in details for Wushka and IXL. Wushka will provide your child with access to readers. IXL will give your child access to a range of numeracy activities. Please use these online platforms as an extra resource.

<https://au.ixl.com/signin/woodfordprimary>

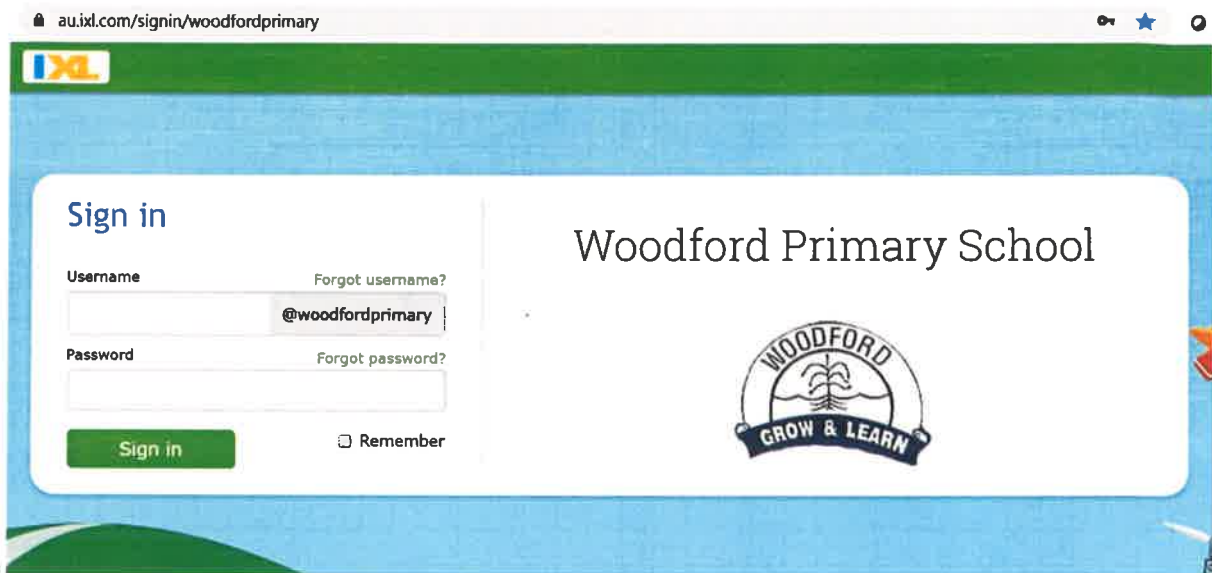

The screenshot shows a web browser window with the address bar displaying "au.ixl.com/signin/woodfordprimary". The page features the IXL logo in the top left corner. The main content area is titled "Sign in" and includes a form with the following elements:

- Username:** A text input field containing "@woodfordprimary". A link "Forgot username?" is located to the right.
- Password:** A text input field. A link "Forgot password?" is located to the right.
- Sign in:** A green button.
- Remember:** A checkbox labeled "Remember".

To the right of the form, the text "Woodford Primary School" is displayed above the school's logo, which features a tree and the motto "GROW & LEARN".

<https://wushka.com.au/login/>

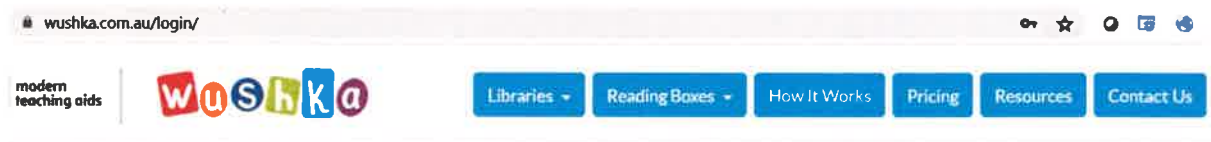

The screenshot shows the header of the Wushka website. The address bar displays "wushka.com.au/login/". The header includes the Wushka logo, the text "modern teaching aids", and a navigation menu with the following items: "Libraries", "Reading Boxes", "How It Works", "Pricing", "Resources", and "Contact Us".

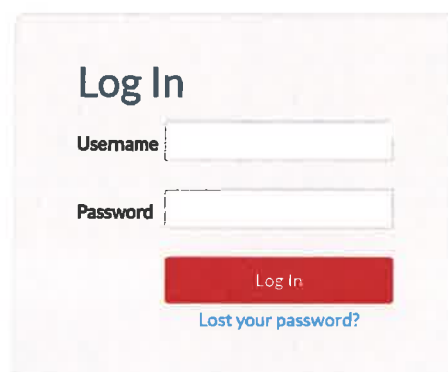

The screenshot shows a "Log In" form with the following elements:

- Log In:** The title of the form.
- Username:** A text input field.
- Password:** A text input field.
- Log In:** A red button.
- Lost your password?:** A blue link below the button.

## Prep/One R Webex Sessions

Optional daily Webex sessions will be provided. This is a time for your child to check in, say hello to their classmates and ask any questions about the activities for the day.

<b>Webex Sessions May 31<sup>st</sup>-June 3<sup>rd</sup></b>			
<b>MONDAY</b>	<b>TUESDAY</b>	<b>WEDNESDAY</b>	<b>THURSDAY</b>
<b>9:00am</b> Optional Daily Webex check in <b>Meeting number:</b> <b>165 902 0198</b> <b>Password: hello</b>	<b>9:00am</b> Optional Daily Webex check in <b>Meeting number:</b> <b>165 902 0198</b> <b>Password: hello</b>	<b>9:00am</b> Optional Daily Webex check in <b>Meeting number:</b> <b>165 902 0198</b> <b>Password: hello</b>	<b>9:00am</b> Optional Daily Webex check in <b>Meeting number:</b> <b>165 902 0198</b> <b>Password: hello</b>

## Webex

Webex is the videoconferencing solution that the Department of Education and Training offers all Victorian government schools.

Here are instructions on how to access Webex meetings provided by your teacher using your internet browser.

You may need to ask your parent or carer to help you access them.

1. Your teacher will provide you with a meeting or class number and a meeting password. This will be 9 digits long (e.g. 123 456 789).
2. Open your internet browser and go to <https://eduvic.webex.com/>
3. Enter the meeting number in the 'meeting information' field and press 'Enter'.
4. Enter the password provided by your teacher, and press 'Enter'.
5. Select the 'Join' or 'Join Meeting' button. If you see a pull-down arrow on the button, click the pull-down and ensure 'Use web app' is selected.
6. When prompted, enter your first name and initial of your last name. Enter an email address. If you don't have an email address, you can enter your parent's email address or a made-up email address. Just make sure that you include an @ symbol. This email address will not be displayed when you join the meeting, and you will not receive emails from Webex at this address.
7. Click 'Join Meeting'.
8. The session will start. You might be asked to allow your microphone and camera to be used in the session. Click 'Allow' then press 'Skip' to continue.
9. Start learning with your peers and teachers, just like at school!

\* Webex meetings can also be accessed via a desktop application. The instructions above are for browser access, however you can download the desktop application from <https://eduvic.webex.com/> or when prompted when joining a meeting from the link you have been sent.



\* Words your child can read and write.

# Oxford Wordlist

## Words 1–100

I	were	fun	can
the	day	like	bought
and	so	some	brother
to	when	have	big
a	home	are	birthday
was	you	out	them
my	at	going	bed
went	me	called	made
we	mum	all	name
on	for	play	too
it	dad	Sunday	next
then	but	upon	dog
he	saw	Saturday	lots
had	house	did	night
in	that	school	not
they	weekend	two	friends
with	time	very	into
of	her	back	an
there	go	ate	park
got	came	get	will
she	because	lived	car
said	up	am	our
played	his	him	do
one	once	watched	sister
is	after	little	be

Oxford Wordlist © Oxford University Press 2008. The Oxford Wordlist may be used for instructional purposes for students at school and home. If you wish to use the Oxford Wordlist in any other way, you must seek written permission from Oxford University Press.

\* Words your child can read and write.

# Oxford Wordlist

## Words 201–307

lot	rabbit	princess	asked
today	five	shopping	OK
beach	turned	until	scary
finished	another	only	every
funny	make	black	walked
book	cousin's	garden	read
bad	breakfast	still	world
things	chips	beautiful	monster
yesterday	door	pool	slide
computer	couldn't	take	thank
help	present	well	white
zoo	together	animals	buy
now	walk	horse	dressed
ride	great	movies	fast
castle	icecream	names	head
toy	loved	bit	walking
cousins	magic	race	why
look	work	sad	blue
more	coming	snake	dogs
tried	someone	jumped	footy
find	team	place	here
four	thing	show	killed
I'm	always	where	need
happily	boat	everyone	playground
started	red	or	that's
dragon	teacher	shark	watch
much	its	something	

Oxford Wordlist © Oxford University Press 2008. The Oxford Wordlist may be used for instructional purposes for students at school and home. If you wish to use the Oxford Wordlist in any other way, you must seek written permission from Oxford University Press.

\* Words your child can read and build using the letter tiles.

<u>Initial Code</u> Unit 11	Sound: /th/ (voiced)		< th >	
that	them	then	than	with
this				

<u>Initial Code</u> Unit 11	Sound: /th/ (unvoiced)		< th >	
moth	thin	theft	cloth	thump
broth	thank	throb	thud	froth
tenth	sixth	width	throng	depth
fifth	thrift	think	thrum	thrill

	New spelling of	
--	-----------------	--

<u>Initial Code</u> Unit 11	Sound: /sh/	< sh >		
fish	gash	rash	rush	wish
shed	dish	shut	cash	shop
shelf	brush	shrub	shift	shred

<u>Initial Code</u> Unit 11	Sound: /ch/		< ch > and < tch >	
chat	champ	chess	chump	chest
crush	shrug	crash	splash	fresh
chin	chips	chop	chum	chunk
rich	finch	winch	lunch	much
pinch	such	chimp	bench	bunch
itch	patch	hutch	fetch	notch
splotch	switch	stretch	catch	witch

s	t	a	i
m	n	o	r
l	c	h	g
d	e	f	v
k	l	u	r
j	w	z	x
y	sh	ch	th

- Cut out the letter tiles. Use the letters to build words. Refer to the wordlist for a list of words your child can build

# Reading Activity- Monday

## **Reading Activity- Tuesday**

## **Reading Activity- Wednesday**



# Reading Activity- Thursday

# Writing the Alphabet

A a B b C c D d

E e F f G g H h

I i J j K k L l

M m N n O o P p

Q q R r S s T t

U u V v W w X x

Y y Z z

Aa Bb Cc Dd Ee Ff Gg Hh Ii Jj Kk Ll Mm



Nn Oo Pp Qq Rr Ss Tt Uu Vv Ww Xx Yy Zz



- Planner to be completed on Monday 31/05/21 for writing

On the weekend... (May 29<sup>th</sup> - 30<sup>th</sup>)

Who



What





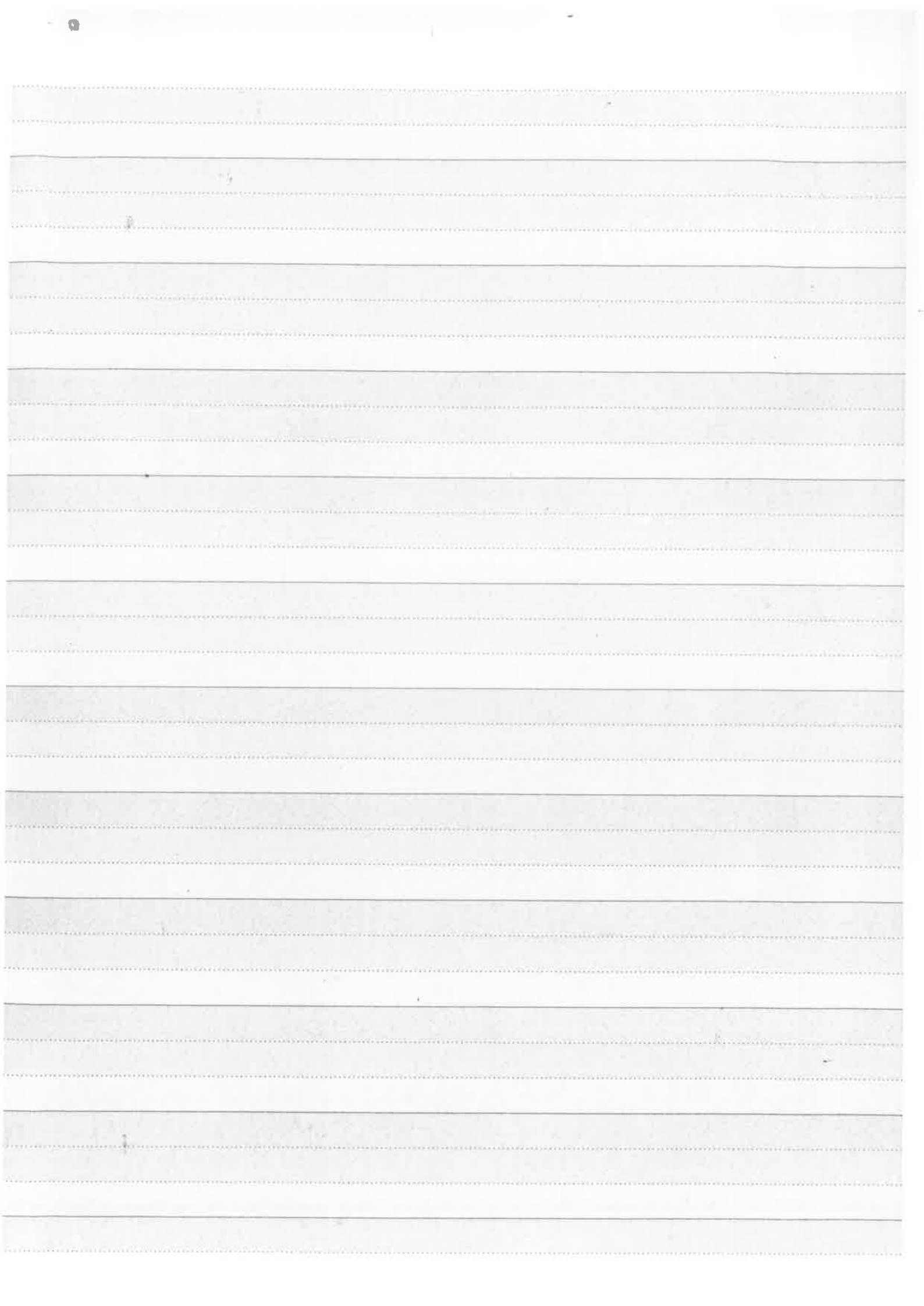

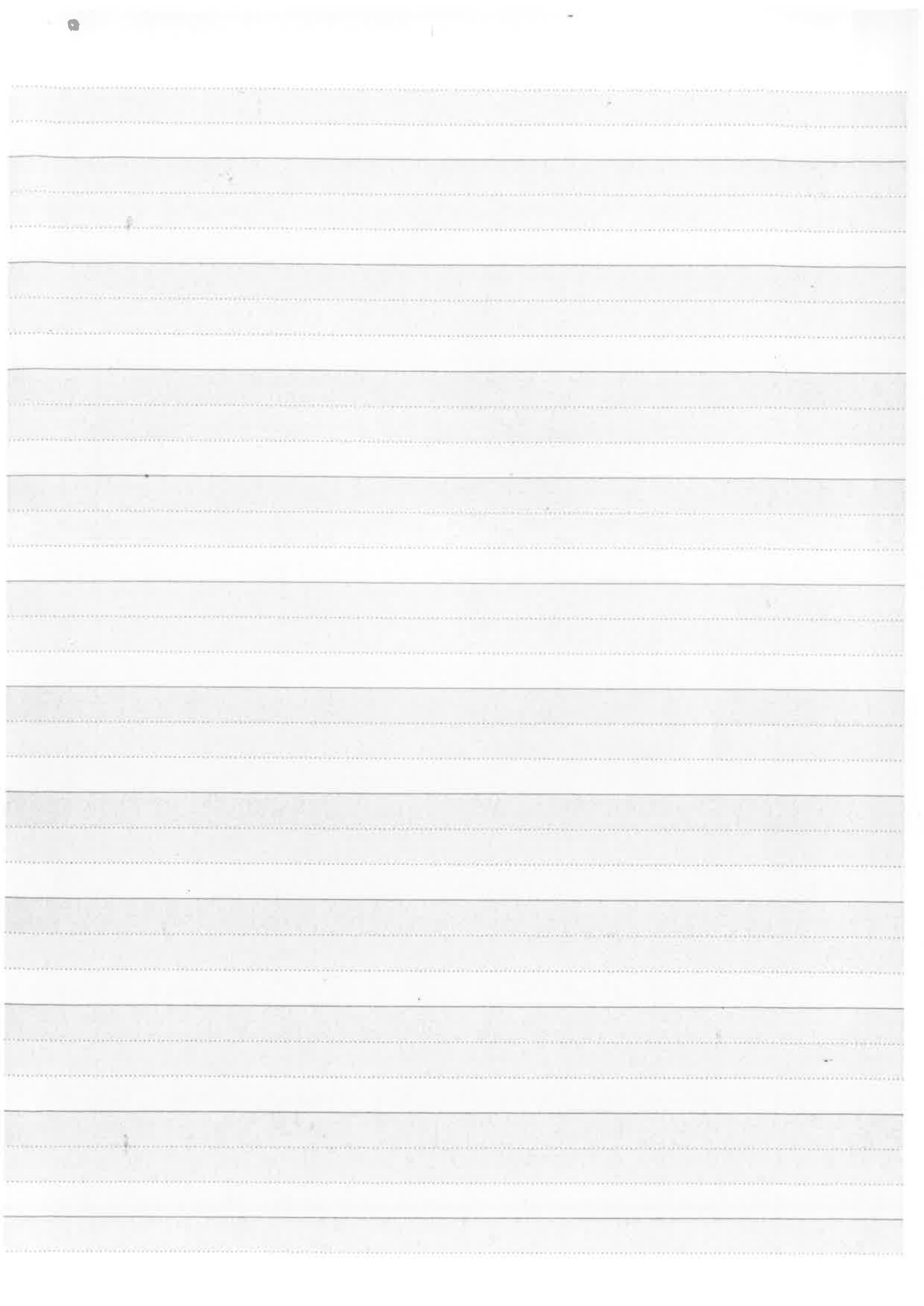

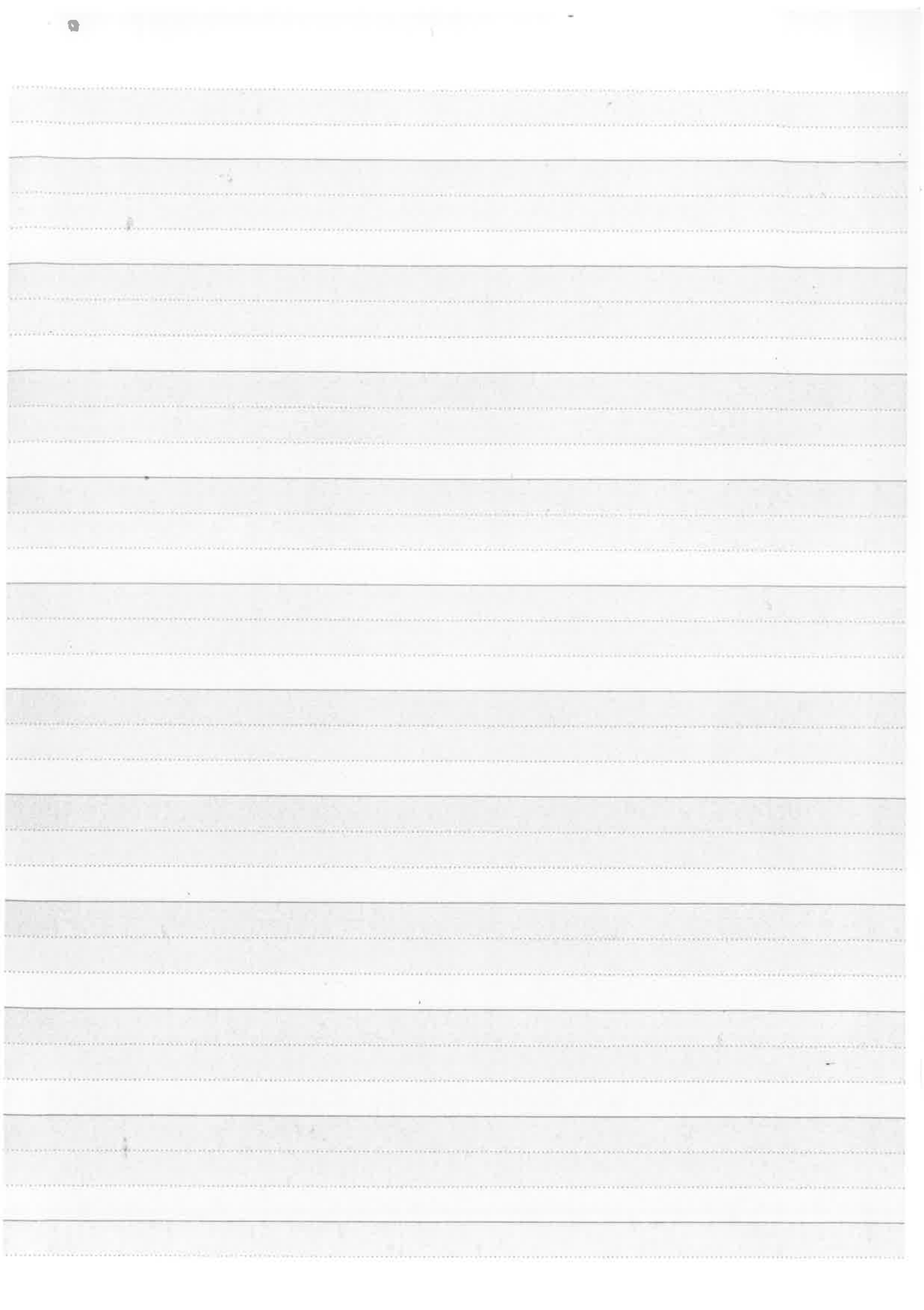

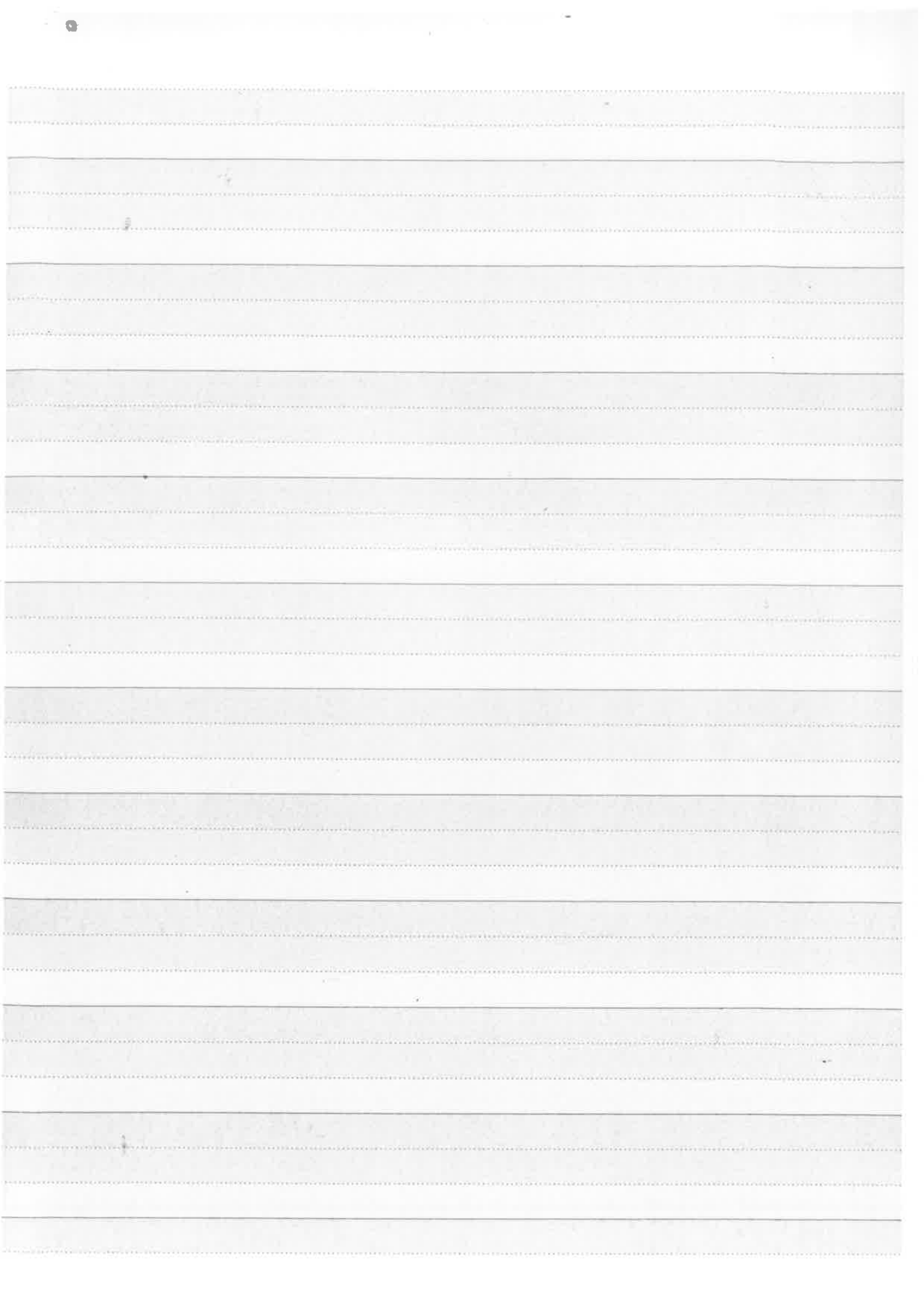



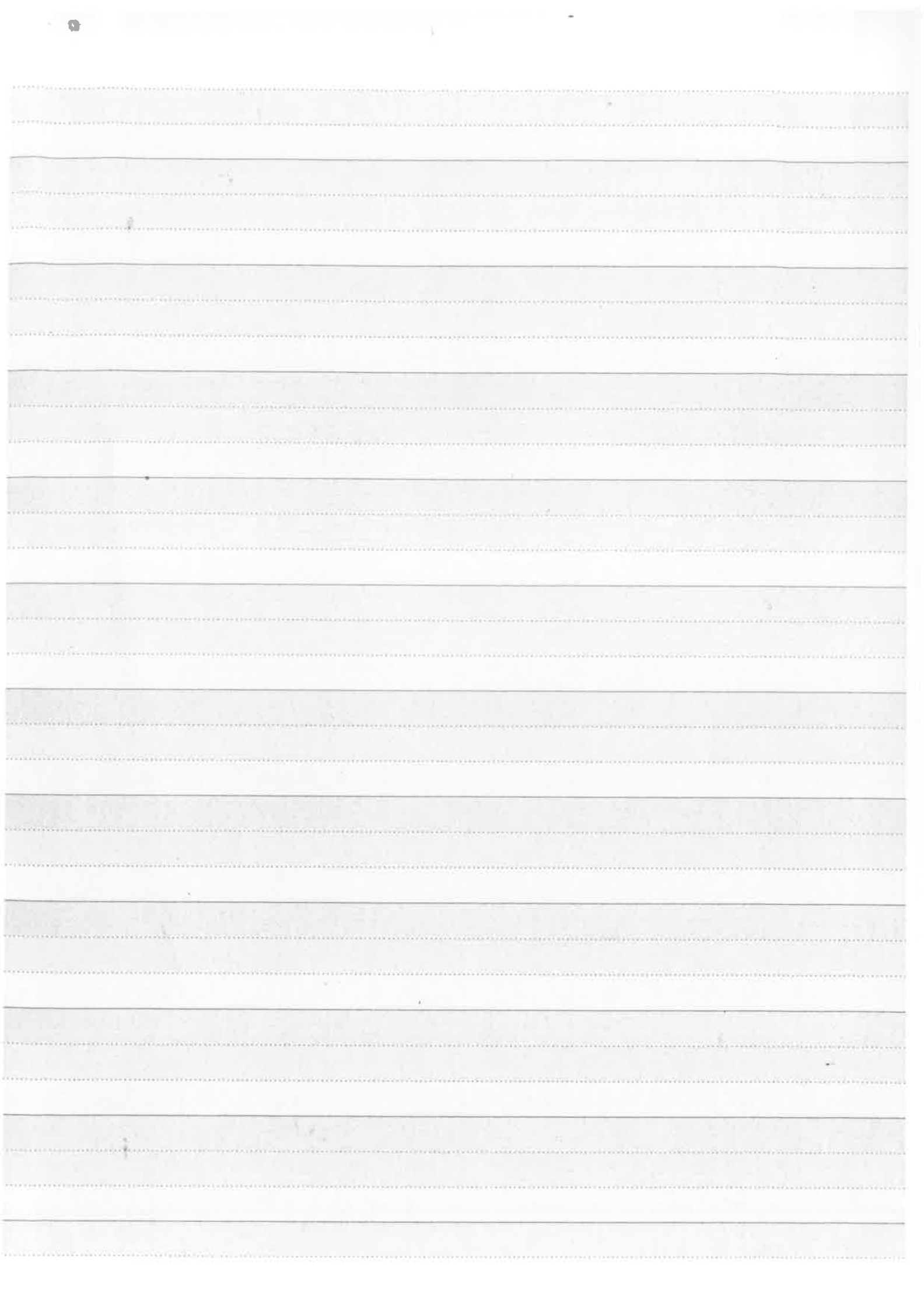

# Practise Your Numbers

1

2

3

4

5

6

7

8

9

10

11

12

13

14

15

16

17

18

19

20

21

22

23

24

25

26

27

28

29

30

# I SPY - LENGTH

Find and draw an object in the classroom that is **longer** than:

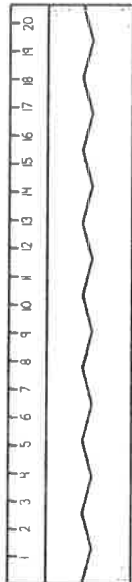
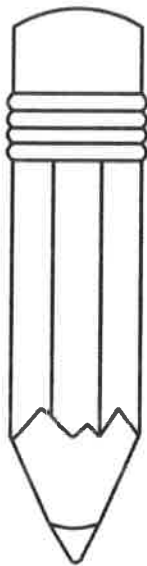

Find and draw an object in the classroom that is **shorter** than:

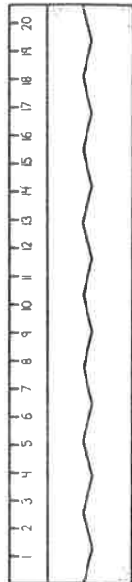

# MEASURE *and* ORDER

Use cubes to measure then order the items from shortest to longest. Glue them in the correct order

--	--	--	--	--	--

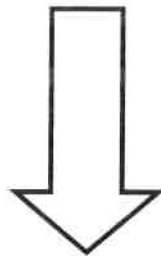

Shortest





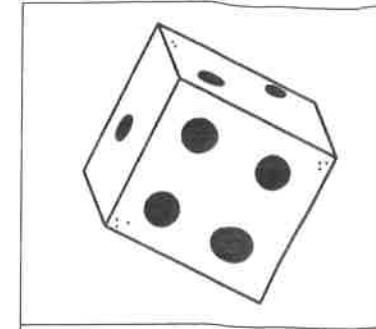
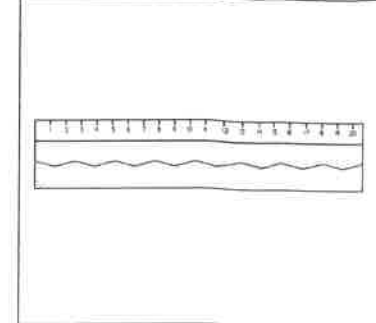
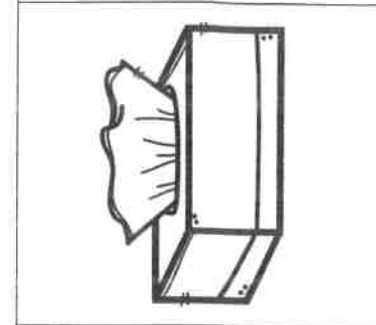
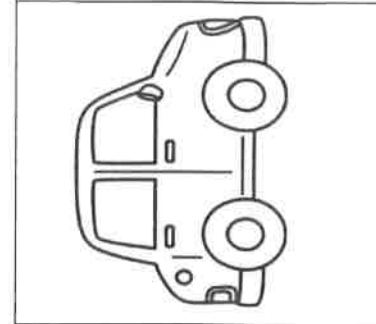
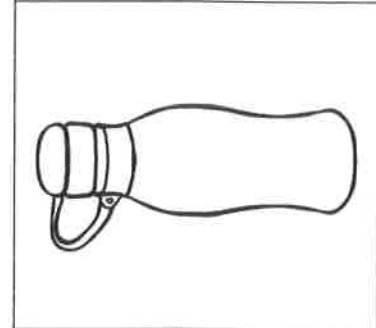
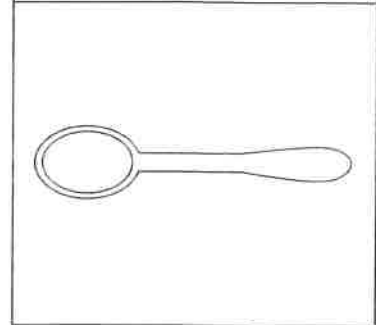

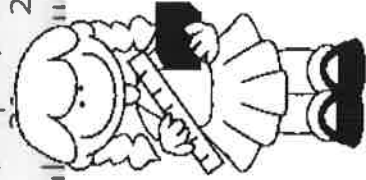
Longest



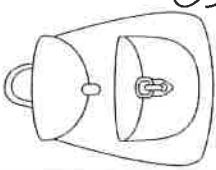
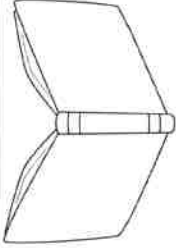
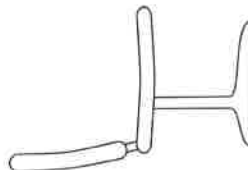

# M e a s u r e t h e R o o m

What will you use to measure the room with?

Item	Estimation	Actual Measurement
 lunchbox		
 ruler		
 school bag		
 book		
 chair		
 glue stick		